

# **BOKARO POWER SUPPLY CO. (P) LTD.**

**HALL NO:- M-01, OLD ADMINISTRATIVE BUILDING,  
ISPAT BHAVAN, BOKARO STEEL CITY – 827001**

**CIN:U40300DL2001PTC112074**

*Reg. Office : Ispat Bhawan, Lodhi Road, New Delhi - 110 003*

**TENDER NOTICE NO. BPSCL/CEO/P&C/16-17/PUR-214/NIT-633/1501**

**Dated 16.03.2017**



## **TENDER DOCUMENT**

**SUBJECT: SCRAPER CHAIN ASSEMBLY**

**COST: Rs. 500/-  
(Rupees Five Hundred Only)**

# INDEX

<b>Sl. No.</b>	<b>Subject</b>	<b>Page No.</b>
<b>1</b>	<b>Cover Page</b>	<b>1</b>
<b>2</b>	<b>Index</b>	<b>2</b>
<b>3</b>	<b>Notice Inviting Tender</b>	<b>3-4</b>
<b>4</b>	<b>Section – I Conditions &amp; Rules to be observed in submitting Tenders.</b>	<b>5-6</b>
<b>5</b>	<b>Section – II General Terms and Conditions</b>	<b>7-8</b>
<b>6</b>	<b>Section – III Instruction Sheet</b>	<b>9</b>
<b>7</b>	<b>Section – IV Description of Material with Special Terms &amp; Conditions</b>	<b>10</b>
<b>8</b>	<b>Part – ‘B’ Techno-Commercial Bid</b>	<b>11-12</b>
<b>9</b>	<b>Part – ‘C’ Price Format for Reverse Auction</b>	<b>13-14</b>
<b>10</b>	<b>Annexure - I Drawings</b>	<b>15-18</b>
<b>11</b>	<b>Annexure - II Notarized Affidavit</b>	<b>19</b>
<b>12</b>	<b>Annexure - III Format for RA Acceptance</b>	<b>20</b>
<b>13</b>	<b>Annexure – IV Format for submitting Last Quoted Price</b>	<b>21</b>

Bokaro Power Supply Company (P) Limited  
(A Joint Venture of SAIL & DVC)  
Hall No. M-01, Old Administrative Building  
Ispat Bhawan, Bokaro Steel City 827 001

**NOTICE INVITING TENDER**

NIT No. BPSCL/CEO/P&C/16-17/PUR-214/NIT-633/1501

Date: 16.03.2017

For and on behalf of BOKARO POWER SUPPLY COMPANY (P) LTD (BPSCL), sealed tenders in three parts, i.e. Cost of Tender Document & EMD (Part A), Techno-Commercial bid (Part-B) and **Online Price bid** (Part -C) are invited from reputed, experienced & financially sound firms for following items.

<b>Material Details:</b>	
<b>Item</b>	<b>SCRAPPER CHAIN ASSEMBLY</b>
<b>Quantity</b>	<b>AS GIVEN IN DESCRIPTION OF MATERIAL (Section-IV)</b>
<b>Material Specification</b>	<b>AS PER SECTION-IV.</b>
<b>Qualifying requirements: -</b>	
1. The tenderer should have minimum average annual turnover (MAT) of <b>Rs. 3,00,000.00</b> (Rupees Three Lakh) <b>only</b> . <ul style="list-style-type: none"><li>➤ Average annual turnover shall be determined taking into consideration turnover of available proceeding three (03) consecutive financial years. Other income shall not be considered for arriving at annual turnover.</li><li>➤ Audited annual account along with auditor's report of the bidder should be furnished in support of the same. Where audited account is not mandatory as per the law, the bidder has to submit annual financial turnover during the consecutive last three (03) years ending 31<sup>st</sup> March of the previous financial year duly certified by CA.</li></ul>	
2. The bidder shall have requisite experience of manufacturing and / or authorized supplier of similar items (Scrapper chain) to any PSU / Government / Semi Government Organization or Joint venture thereof / Company registered under Companies Act.	
3. The bidder shall have infrastructural facilities for carrying out at least one core activity like Machining / Load testing along with assembly required for manufacturing of the item under procurement.	
4. The bidder shall furnish <b>latest IT return &amp; Sales tax registration certificate</b> .	
5. The bidder is required to submit self-attested photocopies of documents in support of their eligibility and experience. In addition, bidder shall submit an affidavit in enclosed format ( <b>Annexure – II</b> ) declaring that the documents submitted by them are genuine.	
6. <b>The bidder must accept for finalization of rates through Reverse Auction.</b>	
<b>Other information: -</b>	
<b>Cost of Tender Paper (non refundable)</b>	<b>Rs. 500.00 (Rupees Five Hundred only)</b>
<b>Last date &amp; time for submission of tender</b>	<b>17.04.2017 up to 12.00 Hours</b>
<b>Bid Opening date &amp; time (Part – A &amp; B)</b>	<b>17.04.2017 at 12.15 PM</b>

**General Terms & Conditions:**

- i) Tenderers should download the tender documents from website [www.bpscl.com](http://www.bpscl.com) / [eps.buyjunction.in](http://eps.buyjunction.in) and submit the duly filled documents along with the cost of tender documents of **Rs. 500/=** by way of demand draft drawn on any nationalized bank/scheduled commercial bank, drawn in favour of **Bokaro Power Supply Co. (P) Ltd**, payable at **Bokaro Steel City**, in the office of the undersigned on any working day during office hours.

- ii) Tender shall be enclosed with **Earnest Money Deposit (EMD)** of **Rs. 5,000.00** (Rupees Five Thousand) **only** in shape of **BG** (as per format available in [www.bpscl.com](http://www.bpscl.com)) having validity up to offer validity plus three (03) months of claim period / **DD / Pay order or Banker's cheque** drawn on any Scheduled Commercial Bank except Co-operative bank and Gramin Bank in favour of **Bokaro Power Supply Company (P) Ltd.**, payable at **Bokaro Steel City**.
- iii) However, Micro & small enterprises (MSEs) / PSU /Govt. Undertakings and Co-operative societies will be exempted from submission of **Cost of tender document & Earnest Money Deposit (EMD)** as per government policy. For MSEs the exemption from paying cost of tender document & Earnest Money will be granted only on submission of valid notarized copy of certificate having a valid Entrepreneurs Memorandum (EM) number.SSI/NSIC certificate holders should also submit a copy of Entrepreneurs Memorandum.
- iv) The undersigned reserves the right to either reject any / all tenders without assigning any reason thereof and also reserve the right to alter the qualifying requirements.
- v) **Any corrigendum/addendum/extension of bid opening date will be published through our website [www.bpscl.com](http://www.bpscl.com) / [eps.buyjunction.in](http://eps.buyjunction.in) only and not through news paper.**

For and on behalf  
Bokaro Power Supply Co. (P) Ltd.  
**Sd/-**  
(J. M. Prasad)  
DGM (P&C)

## Section – I

### 1.00 Conditions & Rules to be observed in submitting Tenders

#### 1.01 Manner of Submission of the Tender

The tender shall be divided into 03 parts as follows:-

- a) **Part - A:** This part Comprises of Cost of Tender documents, EMD, NIT No. & date, marked with **(Part-A)**.
- b) **Part - B:** This part Comprises Technical and Commercial details executed, consent on terms & conditions of NIT along with copy of System generated **acknowledgement-slip** for online submission of sealed price bid etc., marked with **(Part-B)**, Techno-Commercial Bid, NIT No. & Date (*In hard copy*).

**Note: Part A & Part B shall be submitted in hard copy at following address:**

DGM (P&C)  
Bokaro Power Supply Co. (P) Ltd.  
Hall No. – M-01, Old ADM Building  
Ispat Bhawan, Bokaro Steel City – 827 001  
Ph: 06542 – 240380, Mob: 8986874098

- c) **Part - C:** Online sealed price bid to be submitted through URL: <http://www.buyjunction.in>.

**The process of submission of Online Price bid is as detailed hereunder-**

Step 1: Type <http://www.buyjunction.in> in the internet explorer.

Step 2: Click on Login (present on Top right side of the Page)

Step 4: Click on **View Live Auctions and Tenders**.

Step 5: In the right side open/ global tenders link will be displayed.

Step 6: Click on the link for the above mentioned tender link present under Open tenders

Step 7: Click on new user if you are not registered in **buyjunction** earlier. Click on Existing user in-case you have already registered in buyjunction earlier. Existing users can login with their user id and password.

**Please note** foreign bidders are required to select their bidding currency from the drop down available before proceeding further (where ever applicable).

#### **New Users:**

Steps to get your **User Code** and **Password**

1. Click on the required tender link under “**Open Tenders**”
2. Choose your Auction currency in-case any option is coming to select currency. Click on “**New User**”
3. Fill up the “**Registration Form**” and click on “**Submit**”. All fields marked with (\*) are mandatory fields.
4. On submitting the filled-up registration form, an auto generated email will be sent to the email address you have mentioned in the registration form containing your User Code and Password.
5. Changing of password on first login is compulsory.
6. On receipt of the User Code and Password you become an **Existing User**. Now follow the steps of existing user to login to the auction site.

### **Existing Users**

1. Click on the required tender link under “**Open Tender**”
2. Click on “**Existing User**”.
3. Log in with your existing user code and password for placing your bid.
4. Read through the “**Bidding Procedure**” to proceed further for bidding.

### **Bidding Procedure**

After logging in with your user id and password you have to accept the “**Auction Terms**”.

#### **Steps to accept the “Auction terms”:**

1. Click on “**Auction Terms**”.
2. Then click on “**View term without DSC**”
3. Click on the relevant auction terms appearing under “**Term**” column.
4. Select the check box on the left-side of the relevant auction terms.
5. Click on the button besides “**Accept**”.
6. Then click on “**Submit**”.
7. A message will be displayed to you mentioning your acceptance to terms for auction.
8. It is mandatory to accept the terms of online bidding in order to proceed for submission of bid.

#### **Steps to Submit Price Bid**

1. Click on “**Bids.**”
2. Then click on “**Live Auction.**”
3. Put your login password as transaction password
4. Select the auction id and click on add to watch list.
5. Now the bidding screen is visible.

#### **6a. For Template Bidding**

1. Click on **Icon “T”** on left column of bidding screen (Which will appear separately **for each lot**).
2. A template form will open where you need to fill up the price & click on evaluate at the bottom
3. If you want to quote the evaluated price then click on “**confirm**”.
4. After clicking on the confirm button of the template window, your price will appear in the “**New Bid**” box.

#### **6b. For Non-Template Bidding**

1. Fill your Price in the “**New Bid Box**” visible on the bidding screen.
2. Select the check box at the extreme left of the bidding screen
3. Click on “**Submit**” button placed at the bottom left of the screen.
4. Bid once placed will have to be honoured.
5. You will see “**Bid Accepted**” in the “**Result**” column. This indicates that your bid is accepted and registered in the system.

#### **Steps to take a print-out of the receipt**

1. Once you have placed your bid, to download Bid Receipt, kindly click on “**Download**”.
2. Then click on “**Bid Receipt for Open Tender**”.
3. Select the auction to generate receipt.
4. Take print out of the same market-wise (Term List)/ item-wise (Auction list).

#### **Note:**

1. **Current price, Market status, Start Bid Price, Bid Decrement, Effective Price** will not be available.
2. Time remaining for the event to close will be shown under the Bid Summary screen.
3. For any clarification on the bidding process please contact
  - i) Mr. Manish Nandwana \_ 9163348165\_ [manish.nandwana@mjunction.in](mailto:manish.nandwana@mjunction.in)
  - ii) Ms. Monalisa Shaw \_ 9163348297\_ [monalisa.shaw@mjunction.in](mailto:monalisa.shaw@mjunction.in)
  - iii) Mr. Sumit Kumar Das \_ [8873002750](tel:8873002750) [sumit.das@mjunction.in](mailto:sumit.das@mjunction.in), Bokaro Office

**A copy of System generated acknowledgement-slip for Online submission of sealed price bid to be submitted along with Techno-commercial Bid.**

**1.01.1 Part-A and Part-B** should be sealed in separate envelopes, clearly superscribing on the top of each envelope the relevant part number and description along with NIT reference and date of opening and submit all the parts simultaneously in another sealed envelope clearly superscribing NIT reference and date of opening.

### **1.02 Tender Validity Period**

The tender shall be valid at least for **120 (One Hundred Twenty)** days from the date of opening.

### **1.03 General**

- i) The bidder shall complete the Bid Proposal in all respect by inserting correct applicable 'data' in the 'blank box' against each item/Sl. No. positively.
- ii) The tender rates shall be written in English, in ink both words and figures. In the case of any discrepancy between the words & figures of the rates quoted, the rates expressed in words shall be taken as correct. In the case of discrepancy in the Unit Rate and Amount, Unit Rate will govern.
- iii) **All pages of the copies of documents submitted as credentials should be duly signed / self attested (with seal of the company) by representative of the bidder.**
- iv) If the intending tenderer is a Firm or Company, then they shall, in the forwarding letter, mention the number and names of all the partners shall sign before submitting the same unless the Power of Attorney holder has specifically been authorized in this respect.
- v) If any tenderer withdraws his tender before its acceptance or refuses within a reasonable time without giving any satisfactory and acceptable explanation thereof, the tenderer shall be disqualified for making any tender of the BPSCL for a minimum period of one year and the Earnest Money will be forfeited.
- vi) Proprietary Article Certificate (PAC) and Price Reasonable Certificate (PRC) stating that the prices charged are reasonable and the same being charged to all the Govt./Semi govt. organisations/ PSUs including D.G.S.& D. where applicable. Where agent commission is involved, the same in percentage invariably to be indicated.
- vii) Any tender containing false information / particulars shall be liable to be rejected and tenderer found guilty for furnishing false information / particulars may be debarred from future dealings as per prevailing procedure and EMD will be forfeited.
- viii) **Handling of Earnest Money:**
  - a) Earnest Money will be refunded to the un-successful tenderer after finalization of tender and no interest will be paid for the same. **Bidders are requested to submit their bank details for returning of EMD.**
  - b) The amount of Earnest money will be refunded against submission of Security Deposit only in case of successful Tenderer.
- ix) In case the date of tender opening happens to be holiday, the tender will be opened on the next working day at same time.
- x) **Any conditional offer or offer having deviations from our specification & instruction sheets is liable to be rejected.**
- xi) BPSCL reserves the right either to reject any/all the tenders without assigning any reason thereof.

## 2.00 General Terms and Conditions

- 2.01 Specification, quantity, unit rate, taxes, duties, freight, insurance, packaging, forwarding etc. should be mentioned separately and clearly.
- 2.02 Offer is to either type written or by handwritten and in no case partly type written and partly hand written. No corrections, overtyping shall be permitted. If so, the same shall be summarily rejected.
- 2.03 BPSCL reserves the right to call for original documents for verification at any time during tendering, evaluation and / or the execution of the contract. In case of any documents / information submitted by bidder (s) found to be false or containing any misrepresentation of having any fraudulent declaration in it, then in such eventuality, legal action (including cancellation of contract, banning of business dealing, forfeiting of EMD, damages, criminal proceedings etc.) as deemed fit may be initiated by BPSCL against the bidder.
- 2.04 The Tenderer shall quote the unit rate in figures as well as in words. It should be in the format given in **PART 'C'**.
- 2.05 Bank details mentioning account number, bank name, city, branch name and branch code should be mentioned in the offer for NEFT / RTGS payment.
- 2.06 Paying authority – **In-charge (F&A)**, BPSCL but bill in triplicate duly receipted on the revenue stamp with a copy of TC, GC & Packing list etc. are to be submitted to Consignee: In-Charge (Stores), Power Plant, Bokaro Power Supply Company (P) Limited for processing of the same.
- 2.07 Tenderers shall quote their firm rates and no negotiations will be held except with the lowest tenderer, if required.
- 2.08 Supplies must be strictly in accordance with material specifications. Suppliers will be responsible for deviation whatsoever.
- 2.09 a) The supplier will be held responsible for the stores not being sufficiently and properly packed at his expenses for the transport by rail, road and sea; so as to ensure them being free from loss or injury at their destination. This will apply Ex-Godown office also.
- b) Each bale or package delivered under our order shall at the expense of the supplier be distinctly marked with description and quantity of contents with the consignee's name and address with gross weight with the name of supplier and with a distinctive number or mark which is also to be shown for the purpose of identification of the suppliers packing account.
- c) Each bale or package shall contain a packing note quoting the number and date of our order showing its contents in detail.
- 2.10 In accepting the order you are understood to accept to all responsibilities for and infringement in registered design, trademark, patent rights etc.
- 2.11 The supplier has to arrange & bear Transit Insurance charges.**
- 2.12 Where a claim of Sales Tax is preferred and admitted, the supplier must satisfy that he is a registered dealer under Sales Tax Act and Possesses a Certificate of Registration in the firms name in which the supply is made and shall in proof thereof, while submitting bills for payment, furnish the number date and other particulars of such Certificate.
- 2.13 **Security Deposit:** The successful tenderer will have to deposit as security, **10%** of purchase order value for satisfactory execution of the order of in any form - **Bank Guarantee** (as per BPSCL format available at [www.bpscl.com](http://www.bpscl.com)) having validity up to guarantee period of the item to be supplied plus three (03) months of claim period as per BPSCL format, Bank Draft/ Bankers Cheque in favor of Bokaro Power Supply Company (P) Ltd., B.S. City.

The expression satisfactory execution of the order shall mean fulfillment of all obligation arising out of and the guarantees stipulated in the contract. In default at satisfactory execution of the order the security deposit shall be forfeited to the BPSCL.

Any penalty for which the successful tenderer shall be found liable or any liquidated damages which shall be payable to the BPSCL in terms of the Purchase Order/ Contract, shall also be recoverable by the BPSCL from the Security deposit. If such security deposit will not be adequate for the purpose of liquidating the amount of penalty and/or damages as contemplated, the amount in excess thereof shall be deducted from any sum or sums which may be due or may become due to the successful tenderer from the BPSCL on any account whatsoever.

Notwithstanding what has been stated above if the successful tenderer shall have duly performed all his obligation under and the guarantees stipulated in the purchase order / contract and observe all the terms and conditions thereof and no penalty shall have been recoverable from him and / or the BPSCL shall not have suffered any damages whatsoever, then security deposit shall be refunded, on receipt of a certificate from the consignee that there is no claim against the Successful tenderer under the Purchase Order / Contract.

- i) The Parties should clearly indicate their prices firm in all respects till execution of the order and on door delivery basis by Bank approved road transport to BPSCL Stores.
- ii) In case of asking any variation on any account whether raw materials or sales tax or excise duty or transportation etc. will not be treated as firm price on that account and hence parties should state everything clearly.

2.14 **FORCE MAJEURE:** Supplier shall not be considered in default if delay occurs due to cause beyond their control such as acts of God, Natural calamities, Civil wars fire, Strike, Frost, Floods, Riot and Acts of unsurpassed power. Only those causes which have duration of more than seven days shall be considered in force majeure clause. In the event of delay due to such clause the delivery period will be extended for a length of time equal to the period of force majeure of at the option of owner order may be cancelled without any liability what so ever on the part of the owner.

2.15 **Delivery Required:** Within **four (04) months** after approval of QAP by BPSCL (*Party has to submit QAP for approval within 15 days after receipt of purchase order*).

**Note :** Without any specific mention regarding Excise Duty, Freight & Insurance, Sales Tax, packing and forwarding charges, they would be taken as included in the quoted prices and no claim for these would be entertained latter.

Maker's name brand, if any and Country of Origin should be quoted, otherwise tender may be treated as rejected.

**Special Instruction:** Tenders must signify their willingness to submit security deposit. Tender will be opened **17.07.2017 at 12.15 PM**. If it is declared a holiday by BPSCL then in the next working day in the presence of Tenderer's Authorized Representatives, who wish to be present.

2.16 **RATE FINALIZATION:**

Rates shall be finalized through Reverse Auction or through offline negotiation with L-1 bidder at the discretion of BPSCL. The bidder shall submit their price bid through URL <http://www.buyujunction.in>. BPSCL reserves the right to re-launch the reverse action or process the case on the basis of ranking derived from on-line price bid submitted by techno commercially accepted bidders. The tenderers have to submit their acceptance as per enclosed format at **Annexure – III & IV** along with their techno-commercial bid. The schedule and details of reverse auction event shall be communicated by our service provider (**M/s MJunction Service ltd.**) to the techno-commercially accepted bidders.

### **3.0 Instruction Sheet**

- 3.01 Properly authenticated test certificates with all technical details of similar items previously manufactured and tested by a government certified laboratory should be provided along with the bids. The test data should be in conformance with safety norms and IS norms.
- 3.02 Properly authenticated test certificates of each lot of the item by a government certified laboratory should be provided at the time of delivery of the subject items. The test data should be in conformance with IS norms.
- 3.03 Properly authenticated Test & Guarantee certificates should be provided with each shipment of the item.
- 3.04 The guarantee period should be at least twelve (12) months from the date of commissioning or eighteen (18) months after the delivery of the item, whichever is earlier.
- 3.05 For any manufacturing defect discovered during the guarantee period under normal operation, the defective items must be repaired or replaced free of cost.
- 3.06 Tenderer must agree with despatch of materials after duly stamped by inspecting authority.
- 3.07 Acceptance of materials is subject to testing / inspection and fitment in our existing systems.
- 3.08 Tenderer shall agree with Price Basis as **F.O.R. BPSCL Stores**.
- 3.09 Tenderer shall agree with the **Payment terms: 100% against GRN**.
- 3.10 **Delivery:-**
- a) Timely delivery is the essence of the contract.
  - b) In the event of supply not being effected within the contractual delivery schedule given in the order, liquidated damages @ ½ % of the value of the materials with taxes and duties, per week of delay or part thereof, subject to a maximum of 05% is recoverable from the supplier without prejudice to the right of BPSCL to procure the balance material at the risk & cost of the supplier.
  - c) In the event of failure to supply the goods, or part thereof, within the scheduled delivery period, BPSCL reserves the right to cancel the contract part thereof, and if so desired, to purchase the goods from alternate source at the risk and cost of the defaulting supplier.

## **Section – IV**

### **4.0 Description of Material**

<b>Sl. No.</b>	<b>ITEM DESCRIPTION</b>	<b>QUANTITY</b>
<b>1.</b>	<b>Cat. No. - 16700113004 Scrapper Chain Assembly As per GA drawing no. – 167001(N)00065</b>	<b>06 Nos.</b>

#### **Special Terms & Conditions:**

1. Party has to submit QAP for approval by BPSCL before starting the manufacturing
2. Party has to submit QAP within 15 days for approval after receipt of Purchase Order and supply the material within 03-04 months after approval of QAP by BPSCL.
3. The Party has to provide GC, MTC and Breaking Load Test Certificate at the time of supply of material from Govt. approved laboratory.
4. Third party (Stage wise) inspection & breaking load test shall be carried out in the presence of M/s. Lloyds Register Asia as per approved QAP and drawings. Inspection formalities and cost of inspection shall be under party's scope.

**Bokaro Power Supply Company (Pvt.) Limited  
(A Joint Venture of SAIL & DVC)**

**PART 'B'**

**TECHNO-COMMERCIAL BID**

NIT No. BPSCL/CEO/P&C/16-17/ PUR-214/NIT-633/1501

Date: 16.03.2017

Sl. No.	ITEM DESCRIPTION	QUANTITY
1.	Cat. No. - 16700113004 Scrapper Chain Assembly As per GA drawing no. – 167001(N)00065	06 Nos.

**Commercial Terms & Conditions:**

**Manufacturer/ Make of the item(s):**

1. Price Basis:
2. Packing & Forwarding:
3. Excise Duty:
4. Sales Tax/VAT:
5. Freight:
6. Insurance:
7. Service Tax:
8. Delivery Schedule:
9. Payment Terms:
10. Consignee:
  - a) **If Excise Duty is not applicable** - *In-charge (Stores), Power Plant, BPSCL, B.S. City - 827 001.*
  - b) **If Excise Duty is applicable** - As per our internal arrangement for availing CENVAT Credit by BSL/SAIL; Purchase Order will be placed by BPSCL with consignee as “*DGM (Stores) / BSL* on account BPSCL” and the same should be written in the invoice of successful tenderer. All other activities will be carried out by BPSCL.
11. Inspection: a) Stage-wise inspection of the material & Breaking Load Test shall be done by M/s.  
Lloyds Register Asia at the works of successful tenderer as per approved QAP and drawings by BPSCL and the cost of inspection shall be borne by the tenderer.
  - a) Final inspection will be done at our stores after receipt of material.
12. Authenticated Test & Guarantee Certificate must be supplied along with the material.
13. Registered with  
(‘01’ NSIC/ ‘02’ SSI/ ‘03’ NSIC & SSI/ ‘04’ DGS&D/ ‘05’ None)    
Proof for ‘01’ to ‘04’ attached: YES / NO
14. To be furnished
  - (a) Drawing, QAP and other documents within    days of date of the P.O. for approval

15. Testing: At 

--	--

  
('01' Consignee's Site / '2' Works / '03' Govt. Test House/ '04' Govt. Approved Test House/  
'5' Specify if any other)
16. Guaranteed Period:  
a.) ..... months from date of dispatch **OR**  
b.) ..... months from the date of commissioning whichever is earlier  
c.) ..... of running hours.
17. Security Deposit: **10%** of P.O. value in the form of 

--	--

  
('01' BG, '02' Bank Draft, '03' Bankers Cheque)
18. Liquidated Damage: 1/2 % per week subject to maximum 05% of undelivered value.
19. Validity of offer up to: Day          Month          Year  
(Minimum for a period of **120 days** from the date of opening)

**Bokaro Power Supply Company (Pvt.) Limited**  
**(A Joint Venture of SAIL & DVC)**

**PART 'C'**

**PRICE FORMAT**

(To be finalized through Reverse Auction/ Online Price bid also to be submitted with Tender)

**NIT No. BPSCL/CEO/P&C/16-17/ PUR-214/NIT-633/1501**

**Date: 16.03.2017**

Price:

Sl. No.	Item Description	Qty.	Rate (Rs.) (In Fig. & Words)
	<b>Cat. No. - 16700113004</b> <b>Scrapper Chain Assembly</b> <b>As per GA drawing no. – 167001(N)00065</b>	<b>06 Nos.</b>	Online Sealed price Bid to be submitted through URL <a href="http://www.buyjunction.in">http://www.buyjunction.in</a> (Detailed procedure for submission of online Price-bid is attached herewith in Annexure – I)

**Special Instruction –**

1. *In the event of a L1 Bidder backing out prior to placement of order, in addition to forfeiture of EMD the bidder should be suspended for a period of six months from the date of issue of suspension order*
2. *Breakup of quoted unit LCNC (Landed Cost Net of Cenvat) rate shall be submitted by the bidder. In case of refusal of bidder to submit price break up, the bidder shall be suspended for a period of six months from the date of issue of suspension order.*
3. **Price Basis – Rs. per Number on LCNC Basis.**

Price Break Up Format		
Sl. No.		
A	Basic Price	
B	Packing & Forwarding	
C	Excise Duty & Ed. Cess ( <i>as applicable at the time of supply</i> )	
D	Sales Tax (CST / VAT)	
E	Freight	
F	Insurance	
G	Third Party Inspection charge	
H	Any other tax or charges	
<b>I</b>	<b>TOTAL (A+B+C+D+E+F+G+H)</b>	
J	Less: Cenvat on ED & Edu. Cess	
<b>K</b>	<b>LCNC (I - J)</b>	





167-00(N)-00-064

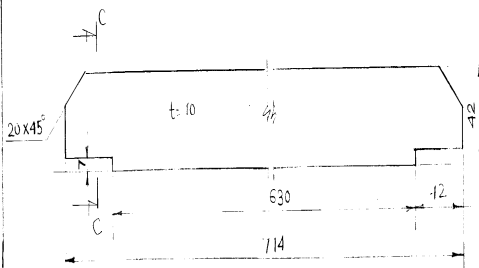
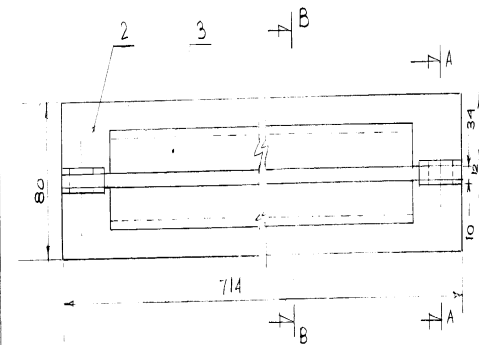
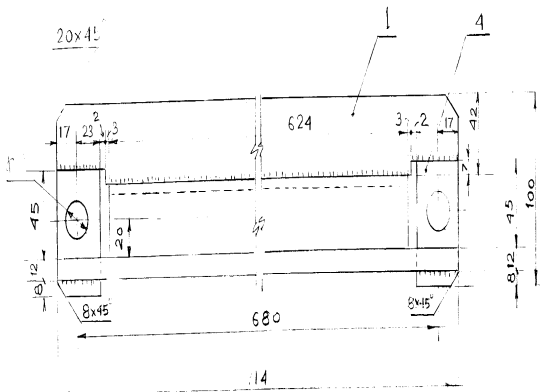

ITEM NO.1  
SC. I.A

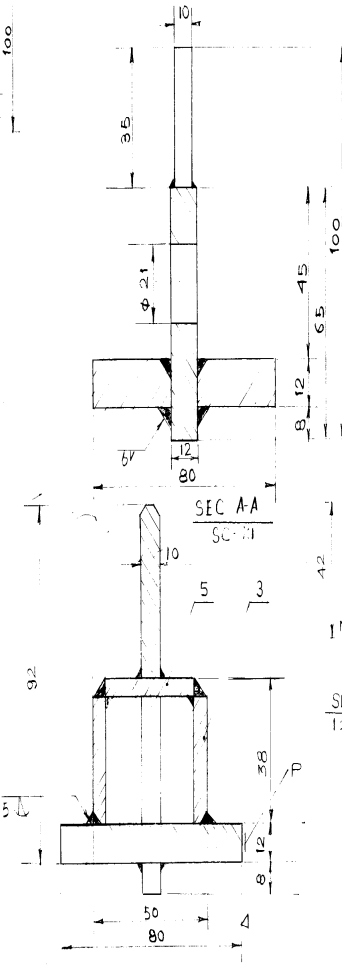

SEC. B.B  
SC. II

**TECHNICAL REQUIREMENTS**

1. WELDING TO BE DONE AS PER IS 8135-83 WITH LOW HYDROGEN ANSWE 7012 OR EQUIVALENT.
2. ITEM TO BE STRESS RELIEVED BEFORE DRILLING HOLES.
3. SHARP EDGES TO BE ROUNDED OFF.
4. SURFACE MARKED BY 'P' TO BE SURFACE HARDENED TO RC 35-40. DEPTH OF HARDNESS TO BE 0.6 TO 1MM.

**NOTE**

POS NO-385 TO BE WELDED TOGETHER TO FORM CHANNEL OF LENGTH 624 MM.

DRG NO	POS NO	DESCRIPTION	QTY	UNIT	TOTAL WT. IN KG	MATERIAL	REMARKS
	5	PL-34X6 L-624	1	16	1.6	35CB IS 5517-93	
	4	PL-40X4 L-65	2	0.2	0.4	35CB IS 5517-93	
	3	PL-28X8 L-624	2	1.1	2.2	35CB IS 5517-93	
	2	PL-80X12 L-714	1	5.1	5.2	45CB IS 5517-93	
	1	PL-42/10 L-714	1	2.2	2.2	35CB IS 5517-93	

DRG NO	DESCRIPTION	QTY	UNIT	MATERIAL	CLASSY DRG NO	SC	DRG NO
14	SCRAPPER	26	IN-8	ASSEMBLY	167-00(N)-00-065	-	167-00(N)-00-064

BOKARO STEEL PLANT	
SHOP	CAPTIVE POWER PLANT
UNIT	R. C. FEEDER-DPR NO: 167-00(N)
DESCRIPTION OF DRAWING	DETAIL OF SCRAPPER
REVISIONS	DRAWN: M.S. / M.M. / M.S. / M.M. / DATE: DEC 2002
	CHECKED: [Signature] / TP. / JOB NO: 167-00(N)
	SUBMITTED: [Signature] / [Signature]
	RECOMMEND: [Signature] / 167-00(N)-00-064
	APPROVED: K.N. JHA / [Signature]

590-000/10-151

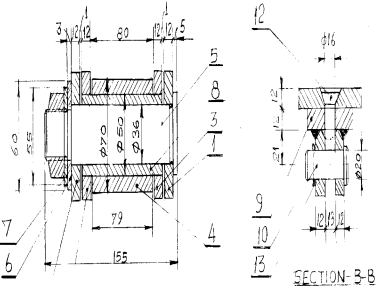
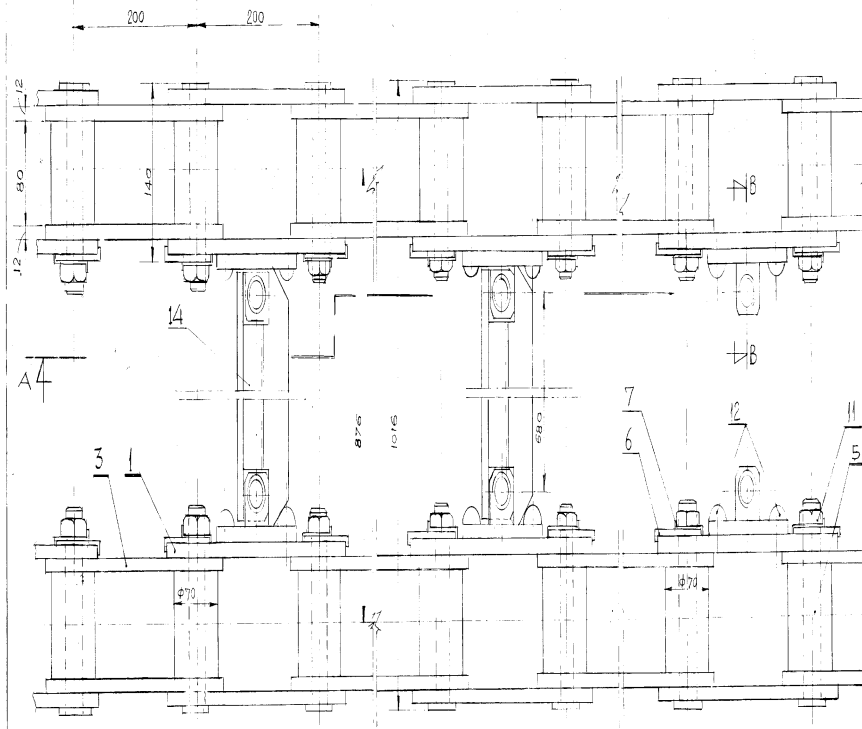
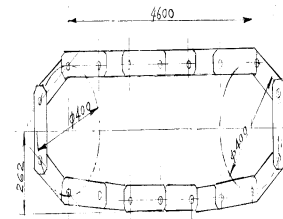
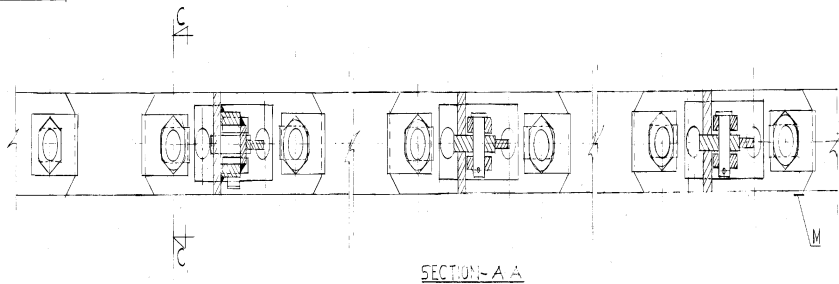

TOTAL LENGTH OF CHAIN = 10400 (APPROX)

REF. DRG. NO. - 157-00(N)/R/C-012A

DRG. NO.	POS. NO.	DESCRIPTION	QTY	MATERIAL	S.A. NO.	SC. DRG. NO.
157-00(N)	00-064	SCRAPPER	21	MS	AS PER	
157-00(N)	00-064	SPLIT PIN 4x4	52	MS	AS PER	
157-00(N)	00-064	RIVET MS 16x38	154	MS	AS PER	
157-00(N)	00-054	LOCKNUT MS 12	52	MS	AS PER	
157-00(N)	00-054	PIN 12x12x1	52	MS	AS PER	
157-00(N)	00-054	CONNECTOR RIVET 12x12	52	MS	AS PER	
157-00(N)	00-057	SLEEVE	52	MS	AS PER	
157-00(N)	00-058	WASHER 50x50x3	104	MS	AS PER	
157-00(N)	00-055	FLAT WASHER 20x20x2	104	MS	AS PER	
157-00(N)	00-059	PIN 12x12x1	104	MS	AS PER	
157-00(N)	00-062	ROLLER	4	MS	AS PER	
157-00(N)	00-063	IN SIDE PLATE	104	MS	AS PER	
157-00(N)	00-060	OUT SIDE PLATE-II	52	MS	AS PER	
157-00(N)	00-061	OUT SIDE PLATE-I	52	MS	AS PER	
157-00(N)	00-061	DESCRIPTION	QTY <td>MATERIAL</td> <td>AS PER</td> <td></td>	MATERIAL	AS PER	

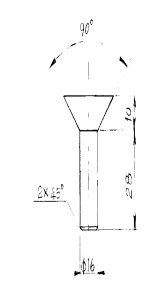

DETAIL OF POS. NO. 12

**CAUTION**

**MATERIAL TESTING:**

FROM BOTH THE SIDES OF CHAIN 2 TO 7 CHAIN LINKS TO BE TESTED BY PULLING & PULLING 4000 KG. IT SHOULD WITHSTAND A TENSILE FORCE OF AT LEAST 45000 KG (45 TONNE)

2. ASSEMBLY INSTRUCTION: SURFACE OF POS. NO. 1, 2, 3, & 14 TREATED TO CASE/SURFACE HARDENING TO BE MARKED BY SYMBOL 'RC' AND CARE SHOULD BE TAKEN TO KEEP THESE SURFACES TO BOTTOM FACE MARKED BY 'M'.

3. IN INSTALLATION OF CHAIN, THE FACE 'M' TO BE KEPT ON DRAGGING/SCRAPPING SURFACE.

APPROVED  
P. R. SINGHA  
A-1 (157-00)-111

NO.	DESCRIPTION	QTY	MATERIAL	S.A. NO.	SC. DRG. NO.																				
1	SCRAPPER CHAIN	104	MS	AS PER	157-00(N)/R/C-012A																				
<table border="1"> <tr> <td>REVISIONS:</td> <td>DATE</td> <td>BY</td> <td>DATE</td> </tr> <tr> <td>CHECKED: J. P. SINGH</td> <td>11/03/17</td> <td>J. P. SINGH</td> <td>11/03/17</td> </tr> <tr> <td>SUBMITTED:</td> <td></td> <td></td> <td></td> </tr> <tr> <td>RECOMMENDED:</td> <td></td> <td></td> <td></td> </tr> <tr> <td>APPROVED: K. N. JHA</td> <td></td> <td></td> <td></td> </tr> </table>						REVISIONS:	DATE	BY	DATE	CHECKED: J. P. SINGH	11/03/17	J. P. SINGH	11/03/17	SUBMITTED:				RECOMMENDED:				APPROVED: K. N. JHA			
REVISIONS:	DATE	BY	DATE																						
CHECKED: J. P. SINGH	11/03/17	J. P. SINGH	11/03/17																						
SUBMITTED:																									
RECOMMENDED:																									
APPROVED: K. N. JHA																									

**ANNEXURE-II**

**Notarized Affidavit**

I.....son/daughter of Shri.....  
Aged.....years resident of.....PS.....  
District.....State.....PAN No.....do hereby  
solemnly affirm that:

- (i) I am.....(designation/authority) in M/s.....  
.....(name of the firm / Company).
- (ii) I confirm that all documents submitted against NIT  
No.....dated.....in support of eligibility criteria  
are genuine.
- (iii) I undertake to produce all documents in original for verification as and when  
asked for the same by BPSCL.

Solemnly affirmed & declared before me by Deponent(s) who is / are identified by.....	The declaration made herein above are true to the best of our knowledge, information and belief Signed at.....on.....  Deponent(s)
---	---

**ANNEXURE-III**

(To be submitted on Supplier's Letter Head)

**Format for Acceptance of General Terms & Conditions, Commercial Terms and all other Terms of the Reverse Auction**

We \_\_\_\_\_ (Supplier Name),  
\_\_\_\_\_ (PAN Number) having registered office at \_\_\_\_\_  
\_\_\_\_\_ (Address) agree to all the Commercial, General & other  
Terms & Conditions listed in the  
NIT No. \_\_\_\_\_  
dated \_\_\_\_\_  
for procurement of \_\_\_\_\_ (item) through Reverse Auction.

We confirm that we are in a position to supply material as per the specification given in RFQ. We agree to participate in the Reverse Auction and abide by the rules.

We nominate an executive, whose details are given below, to put the bids on our behalf.

The details of the person authorized to bid on our behalf is as follows.

Name & Designation :  
E-mail ID :  
Contact phone nos. :  
Address :

(Signature & Seal)  
Place :  
Date :

**ANNEXURE-IV**

**Format for submitting last quoted prices**

*(To be submitted on Company Letter Head of the Bidder)*

**(To be sent within 30 mins of conclusion of the Reverse Auction)**

To,  
mjunction services limited  
1<sup>st</sup> Floor, Tata Centre  
43, Jawaharlal Nehru Road  
Kolkata – 700 071

**Fax: 033 – 2288 3279**

**Ref: Reverse Auction for .....for Bokaro Power Supply Co. (P) Ltd. held on .....**

Reference above, we hereby confirm our Market wise last quoted prices in the Reverse Auction held on ..... for .....for Bokaro Power Supply Co. (P) Ltd., Bokaro Steel City.

<b>Market No.</b>	<b>Last Quoted Price</b>

We also confirm that we will submit item wise price break-up, within two working days from the date of Reverse Auction.

Signature :

Name :

Designation :

Date :